

Implementing Ultrasonic Ranging

*Author: Robert Schreiber
Microchip Technology Inc.*

INTRODUCTION

Object ranging is essential in many types of systems. One of the most popular ranging techniques is ultrasonic ranging. Ultrasonic ranging is used in a wide variety of applications including:

- Autofocus cameras
- Motion detection
- Robotics guidance
- Proximity sensing
- Object ranging

This application note describes a method of interfacing PIC16CXXX microcontrollers to the Polaroid 6500 Ranging Module. This implementation uses a minimum of microcontroller resources, a CCP module and two I/O pins. The two major components of the system are:

- Microcontroller
- Polaroid 6500 Ranging Module

The microcontroller performs the intelligence and arithmetic functions for ultrasonic ranging, while the Polaroid 6500 Ranging Module performs the ultrasonic signal transmissions and echo detection.

FIGURE 1: RANGING MODULE INTERFACE

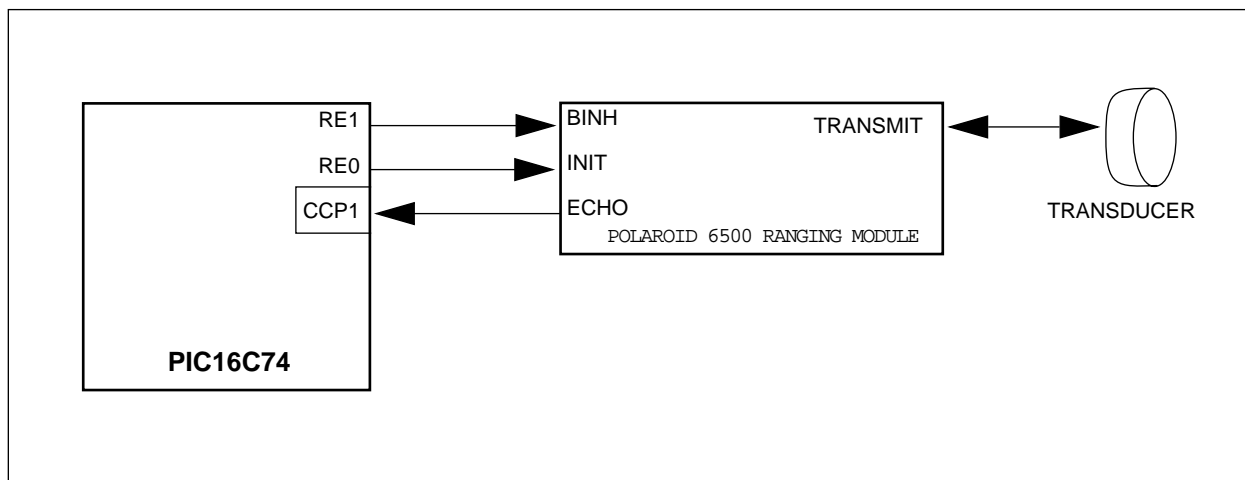

THEORY OF OPERATION

Ultrasonic ranging entails transmitting a sound wave and measuring the time that it takes for the sound wave to reflect off of an object and back to the origin. The reflection time is proportional to the distance that the object is from the source. In this implementation, the sound wave is transmitted and received from the same transducer. Therefore, a blanking interval is required between signal transmission and reception to eliminate false echoes (i.e., a transmitted signal being detected as its own echo).

CIRCUIT CONFIGURATION

In this implementation, a PIC16C74 is connected to the ranging module as shown in Figure 1. The RE0 and RE1 I/O pins are configured as digital outputs and are tied to INIT and BINH, respectively. The CCP1 pin is configured as a digital input and is tied to ECHO through a pull-up resistor. The pull-up resistor is needed since the ECHO signal is an open-collector output. The CCP1 pin is configured for capture mode (CCP1CON). Figure 2 shows the timing relationship for V_{DD} and the three signal lines (INIT, BINH, and ECHO).

Note: The ranging module requires 5.0 milliseconds to stabilize during power-up.

FIGURE 2: TIMING DIAGRAM OF RANGING MODULE CONTROL LINES

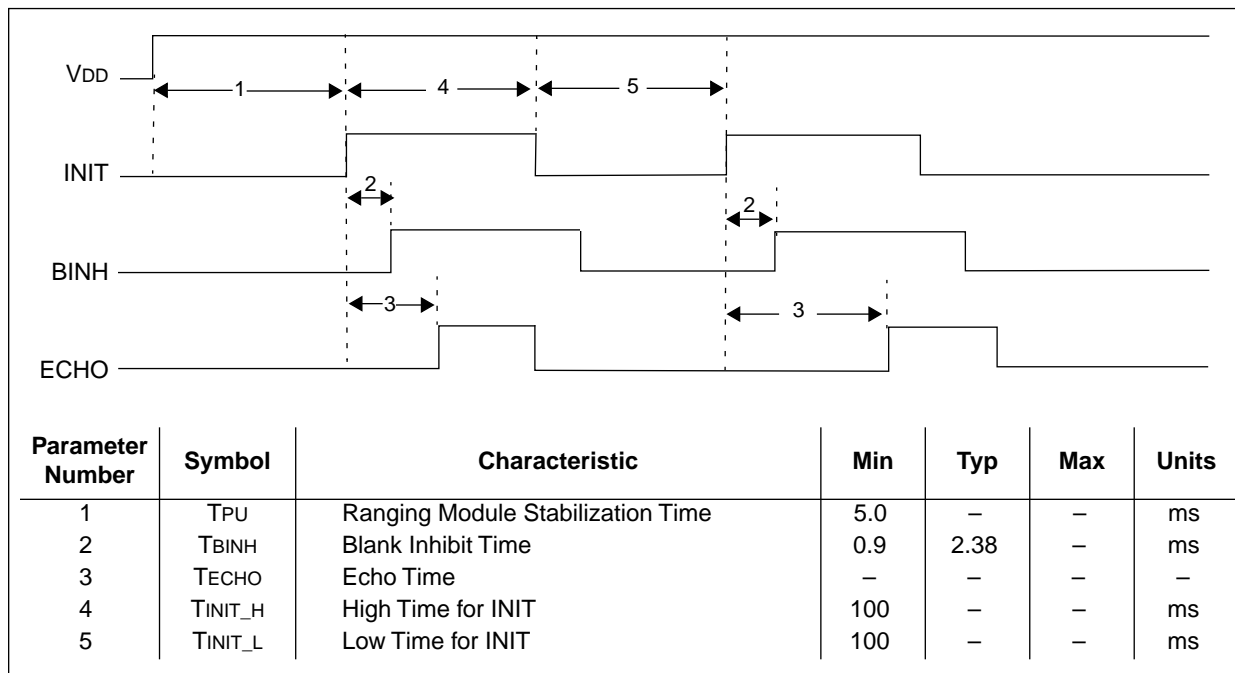

The PIC16C74 is configured to use one of its internal timers, Timer1, in capture mode to measure the time between signal transmission and echo detection. The resolution of the timer is determined by the microcontroller clock frequency. For this application, a 4 MHz external oscillator was used, giving a resolution of 1 ms per bit. The PIC16C74 initiates a ranging cycle by first clearing Timer1. Timer1 is then enabled and INIT is immediately asserted on the ranging module. When INIT is asserted, the ranging module transmits a series of 16 pulses on the transducer at 49.4 kHz. The transmitted pulses reflect off the object and are received back at the transducer.

The transducer is used for both transmitting and receiving sound waves. A blanking interval is needed to ensure that the transmitted signal has decayed on the transducer, in order not to receive false echoes. In normal operation, the ranging module has a blanking interval of 2.38 milliseconds, which corresponds to a minimum detection distance of approximately 17 inches. However, the BINH (blank inhibit) signal can be manipulated to reduce the blanking time on the transducer to allow for object ranging as close as 6 inches.

In this implementation, the PIC16C74 asserts the BINH signal approximately 0.9 milliseconds after signal transmission. This enables the transducer to receive reflections off objects at a distance of 6 inches. The ranging module asserts the ECHO signal when a valid reflection has been detected. The PIC16C74 uses the ECHO signal to trigger a capture of the Timer1 value. The capture register contains the 16-bit value

representing the elapsed time between signal transmission and echo detection. The PIC16C74 then calculates object distance based on the Timer1 value, microcontroller clock speed, and the velocity of sound in the atmosphere. The basic equation for calculating distance is given below:

$$\text{Distance (inches)} = \text{TECHO time} / 147.9 \text{ microseconds}$$

Note: The minimum high and low time for INIT is 100 milliseconds, as seen in Figure 2.

DESIGN CONSIDERATIONS

There are several design considerations which must be taken into account and are listed below.

The absolute measuring distance supported by the ranging module is 6 inches to 35 feet with an accuracy of +/- 1%.

The distance output from the ranging module can be averaged over time to filter distance calculations.

In some applications, the gain of the receiver amplifier may be too low or too high and may need to be adjusted. For example, if the transducer is mounted in a cylinder, the gain may need to be lowered to reduce false echoes within the cylinder. In this case, R1 (refer to the Polaroid Ultrasonic Ranging System manual) may be replaced with a 20 kΩ potentiometer to tweak the gain of the receiver amplifier to reduce false echoes.

In order for the Polaroid 6500 ranging module to operate properly, the power supply must be capable of handling high current transients (2.5 A) during the

transmit pulse. The instantaneous drain on the power supply can be mitigated by installing a storage capacitor across the power lines at the ranging module. A value of 500 microfarads is recommended.

A 200 millisecond interval is recommended between ranging cycles (Figure 2) to allow the transducer to clear.

The ECHO line requires a pull-up resistor (4.7 k Ω was used in this application).

There must be a common ground between the PIC16C74 circuitry and the ranging module.

Some applications may not need the resources of the higher end PIC16CXXX devices. It is still possible to do this application using a device that does not contain a CCP module (for ECHO timing). The capture function can be implemented in firmware. The effect of a firmware implementation is that the resolution of the ECHO time would be 3 T_{cy} cycles versus 1 T_{cy} cycle for the CCP module. Also, the firmware implementation would not allow other tasks to be performed while the capture function was occurring.

Refer to Appendix A for general ranging module specifications.

APPENDIX A: POLAROID MODULE SPECIFICATIONS

Note: This appendix contains general specifications from the Polaroid Ultrasonic Ranging System Manual. Please refer to the current Polaroid Ultrasonic Ranging System Manual for current information regarding ranging module design considerations.

DESIGN CONSIDERATIONS IN ULTRASONICS

Range: (with user custom designed processing electronics)

Farther

- a) Use an acoustic horn to “focus” the sound (narrowing the beamwidth).
- b) Use two transducers – 1 receiver and 1 transmitter – facing each other.
- c) Lower the transmitting frequency (which will decrease the attenuation in air).

Closer

- a) Use a shorter transmit signal (such as four cycles).
- a) Use two transducers – one to transmit, one to receive (eliminates waiting for damping time).

Resolution

- a) Above all, know the target and range well, and design a system with them in mind.
- b) Use a higher transmit frequency.
- c) Look at phase differences of a given cycle of the transmitted signal and received echo (as opposed to using an integration technique).
- d) Increase the clock frequency of the timer.

Accuracy: (again, you must have a well defined target)

Temperature Compensate

- a) Use a second small target, as a reference, at a known distance in the ranging path (such as a 1/4” rod several feet away), process both echoes, then normalize the second distance with respect to the first, since $t1/d1 = t2/d2$.
- b) Incorporate a temperature sensing integrated circuit to drive a VCO to do the distance interval clocking.
- c) To increase sensitivity of detection circuit change the value of C4 from 3300 pF to 1000 pF on the 6500 Series Ranging Module.

Beam Width:

Increase

- a) Use an acoustic lens (to disperse the signal).
- b) Decrease the transmitting frequency.
- c) Use several transducers to span an area.

Decrease

- a) Use an acoustic horn (to focus the sound).
- b) Increase the transmitting frequency.

TABLE 1: RECOMMENDED OPERATING CONDITIONS

		Min.	Max.	Unit
Supply Voltage, Vcc		4.5	6.8	V
High-level input voltage, VIH	BINH, INIT	2.1	—	V
Low-level input voltage, VIL	BINH, INIT	—	0.6	V
ECHO and OSC output voltage		—	6.8	V
Delay time, power up to INIT high		5	—	ms
Recycle period		80	—	ms
Operating free-air temperature, TA		0	40	°C

TABLE 2: ELECTRICAL CHARACTERISTICS OVER RECOMMENDED RANGES OF SUPPLY VOLTAGE AND OPERATING FREE-AIR TEMPERATURE (UNLESS OTHERWISE NOTED)

Parameter		Test Conditions	Min.	Typ.	Max.	Unit
Input current	BINH, INIT	V1 = 2.1V	—	—	1	mA
High-level output current, I _{OH}	ECHO, OSC	V _{OH} = 5.5V	—	—	100	μA
Low-level output voltage, V _{OL}	ECHO, OSC	I _{OL} = 1.6 mA	—	—	0.4	V
Transducer bias voltage		T _A = 25°C	—	200		V
Transducer output voltage (peak-to-peak)		T _A = 25°C	—	400		V
Number of cycles for XDCR output to reach 400V		C = 500 pF	—	—	7	
Internal blanking interval			—	2.38*	—	ms
Frequency during 16-pulse transmit period	OSC output		—	49.4*	—	kHz
	XMIT output		—	49.4*	—	
Frequency after 16 pulse transmit period	OSC output		—	93.3*	—	kHz
	XMIT output		—	0	—	
Supply current, I _{CC}	During transmit period		—	—	2000	mA
	After transmit period		—	—	100	

* These typical values apply for a 420 kHz ceramic resonator.

AN597

Please check the Microchip BBS for the latest version of the source code. Microchip's Worldwide Web Address: www.microchip.com; Bulletin Board Support: MCHIPBBS using CompuServe® (CompuServe membership not required).

APPENDIX B: FIRMWARE LISTING

MPASM 01.40 Released XDCR.ASM 1-22-1997 10:55:26 PAGE 1

```
LOC OBJECT CODE      LINE SOURCE TEXT
VALUE

00001 ; XDCR.ASM
00002 ;
00003 ; This routine continually executes ranging cycles in the
00004 ; following order:
00005 ;
00006 ;      1) Timers and Flags are cleared
00007 ;      2) Ranging Cycle Executes
00008 ;      3) Distance is Calculated (to 0.5 inch)
00009 ;      4) HW is re-initialized for next cycle
00010 ;
00011 ; The processor uses a 4MHz oscillator, so all timing
00012 ; calculations are referenced to that. The calculated
00013 ; distance is a 16-bit result in the ACCbHI:ACCbLO registers.
00014 ;
00015 ;      Program:      XDCR.ASM
00016 ;      Revision Date:
00017 ;                  1-22-97      Compatibility with MPASMWIN 1.40
00018 ;
00019 ;
00020
00021      LIST P=16C74
00022 ;
00001      LIST
00002 ; P16C74.INC Standard Header File, Version 1.00 Microchip Technology, Inc.
00318      LIST
00025
00000030 00026 TEMP equ 0x30 ;Temporary storage location
00000031 00027 TEMP1 equ 0x31 ;Temporary storage location
00000032 00028 TEMP2 equ 0x32 ;Temporary storage location
00000033 00029 TEMP3 equ 0x33 ;Temporary storage location
00000034 00030 COUNT1 equ 0x34 ;Temporary count register
00000035 00031 COUNT2 equ 0x35 ;Temporary count register
00032 ;
00033 #DEFINE XDCR ; Flag for conditional assemble of test code
00034 ; in file DBL_DIVF.ASM. END directive MUST be
00035 ; commented out in file DBL_DIVF.ASM
00036 ;
00037 ;*****
00038      LIST
00039
00040 ;*****
00041 ; Bank 0 Registers
00042 ;*****
00043 ;
00044 ; TMR1 is off, Prescaler is 1 for a capture timeout of 65 msec
0000 0190 00045 clrf T1CON
00046 ; Set to capture on every rising edge
0001 3005 00047 movlw 0x05
0002 0097 00048 movwf CCP1CON
00049 ; Clear the Ports
0003 0185 00050 clrf PORTA
0004 0186 00051 clrf PORTB
0005 0187 00052 clrf PORTC
0006 0188 00053 clrf PORTD
```

```

0007 0189      00054      clrf      PORTE
                00055 ;
                00056 ;*****
                00057 ; Bank 1 Registers
                00058 ;*****
                00059 ;
0008 1683      00060      bsf       STATUS,RP0      ; Set Bank1
                00061 ; Port A is Digital, Port E is Digital
0009 3007      00062      movlw    0x07
Message[302]: Register in operand not in bank 0.  Ensure that bank bits are correct.
000A 009F      00063      movwf    ADCON1
                00064 ; Configure CCP1 (RC2) as an input, and all other ports
                00065 ; as Outputs, (RE0 = INIT, RE1 = BINH)
Message[302]: Register in operand not in bank 0.  Ensure that bank bits are correct.
000B 0185      00066      clrf     TRISA
Message[302]: Register in operand not in bank 0.  Ensure that bank bits are correct.
000C 0186      00067      clrf     TRISB
000D 3004      00068      movlw    0x04
Message[302]: Register in operand not in bank 0.  Ensure that bank bits are correct.
000E 0087      00069      movwf    TRISC
Message[302]: Register in operand not in bank 0.  Ensure that bank bits are correct.
000F 0188      00070      clrf     TRISD
Message[302]: Register in operand not in bank 0.  Ensure that bank bits are correct.
0010 0189      00071      clrf     TRISE
0011 1283      00072      bcf      STATUS,RP0      ; Clear RP0
0012           00073 Xdcr
                00074 ;
                00075 ; Initialize Timers and Flags
                00076 ;
0012 1010      00077      bcf      T1CON,0 ; Disable TMR1
0013 018C      00078      clrf     PIR1      ; Clear Timer1 Overflow Flag & Timer1 Capture Flag
0014 018E      00079      clrf     TMR1L     ; Clear TMR1L
0015 018F      00080      clrf     TMR1H     ; Clear TMR1H
0016 0195      00081      clrf     CCP1L     ; Clear CCP1L
0017 0196      00082      clrf     CCP1H     ; Clear CCP1H
0018 1409      00083      bsf      PORTE,0 ; Set INIT High on Ranging Module
0019 1410      00084      bsf      T1CON,0 ; Enable TMR1
001A 21F3      00085      call    DEL_9      ; Delay 0.9 msec for transducer to stabilize
001B 1489      00086      bsf      PORTE,1 ; Enable Transducer to Receive (BINH)
001C           00087 chk_t1
001C 190C      00088      btfsc   PIR1,2      ; Check for Capture
001D 2822      00089      goto    chk_done    ; Jump if Capture
001E 1C0C      00090      btfss   PIR1,0      ; Check for TMR1 Overflow
001F 281C      00091      goto    chk_t1      ; Loop if nothing happened
0020 1010      00092      bcf      T1CON,0    ; Turn off TMR1
0021 2833      00093      goto    ovr_flo     ; Capture event did not occur
0022           00094 chk_done
                00095 ;
                00096 ; Calculate distance to 0.5 inch resolution
                00097 ;
0022 1010      00098      bcf      T1CON,0    ; Turn off TMR1
0023 0815      00099      movf    CCP1L,W     ; Move LSB into W
0024 00A2      00100      movwf   ACCbLO      ; Move LSB into ACCbLO
0025 0816      00101      movf    CCP1H,W     ; Move MSB into W
0026 00A3      00102      movwf   ACCbHI      ; Move MSB into ACCbHI
0027 304A      00103      movlw   0x4A        ; Move 75usec/0.50in into W
0028 00A0      00104      movwf   ACCaLO      ; Move LSB into ACCaLO
0029 01A1      00105      clrf    ACCaHI      ; Clear MSB (ACCaHI)
002A 208F      00106      call    D_divF      ; Call 16-bit/8-bit routine
                00107 ;
                00108 ; which is described in
                00109 ; Application Note 544
002B 3025      00109      movlw   0x25        ; Check remainder to see if
002C 0224      00110      subwf   ACCcLO,W    ; we should round up...
002D 1803      00111      btfsc   STATUS,C    ; If Remainder < (0.5 * Divisor), skip
002E 00A2      00112      incf    ACCbLO,F    ; Round up
002F 1903      00113      btfsc   STATUS,Z    ; Check low byte for wrap around
0030 00A3      00114      incf    ACCbHI,F    ; If LSB wrapped, increment high byte

```

AN597

```
0031 1D03      00115      btfss  STATUS,Z      ; Check high byte for wrap around
0032 2835      00116      goto   done          ; High byte didn't wrap
0033           00117  ovr_flo
0033 01A2      00118      clrf   ACCbLO
0034 01A3      00119      clrf   ACCbHI
0035           00120  done
0035 21FD      00121      call   DEL_100      ; Wait 100 msec before clearing HW.
0036 1009      00122      bcf   PORTE,0      ; Disable INIT
0037 1089      00123      bcf   PORTE,1      ; Disable BINH
0038 21FD      00124      call   DEL_100      ; Wait 100 msec before enabling HW.
0039 2812      00125      goto   Xdcr
                00126
                00319      LIST
                00320
                00636      LIST
                00044
00000001      00045  TRUE   equ    1h
00000000      00046  FALSE  equ    0h
                00047
0080           00048      org    0x080
                00049 ;*****
00000000      00050  SIGNED equ    FALSE      ; Set This To 'TRUE' if the routines
                00051 ;                               ; for Multiplication & Division needs
                00052 ;                               ; to be assembled as Signed Integer
                00053 ;                               ; Routines. If 'FALSE' the above two
                00054 ;                               ; routines ( D_mpy & D_div ) use
                00055 ;                               ; unsigned arithmetic.
                00056 ;*****
                00057 ;       division macro
                00058 ;
00059 divMac  MACRO
00060          LOCAL  NOCHK
00061          LOCAL  NOGO
                00062 ;
00063          bcf   STATUS,C
00064          rlf   ACCdLO, F
00065          rlf   ACCdHI, F
00066          rlf   ACCcLO, F
00067          rlf   ACCcHI, F
00068          movf  ACCaHI,W
00069          subwf ACCcHI,W      ;check if a>c
00070          btfss STATUS,Z
00071          goto  NOCHK
00072          movf  ACCaLO,W
00073          subwf ACCcLO,W      ;if msb equal then check lsb
00074  NOCHK   btfss STATUS,C      ;carry set if c>a
00075          goto  NOGO
00076          movf  ACCaLO,W      ;c-a into c
00077          subwf ACCcLO, F
00078          btfss STATUS,C
00079          decf  ACCcHI, F
00080          movf  ACCaHI,W
00081          subwf ACCcHI, F
00082          bsf  STATUS,C      ;shift a 1 into b (result)
00083  NOGO   rlf   ACCbLO, F
00084          rlf   ACCbHI, F
00085 ;
00086          ENDM
                00087 ;
00088 ;*****
00089 ;       Double Precision Divide ( 16/16 -> 16 )
00090 ;
00091 ; ( ACCb/ACCa -> ACCb with remainder in ACCc ) : 16 bit output
00092 ; with Quotient in ACCb (ACCbHI,ACCbLO) and Remainder in ACCc
00093 ; (ACCcHI,ACCcLO).
00094 ; NOTE : Before calling this routine, the user should make sure that
```



```

00095 ;           the Numerator(ACCb) is greater than Denominator(ACCa). If
00096 ;           the case is not true, the user should scale either Numerator
00097 ;           or Denominator or both such that Numerator is greater than
00098 ;           the Denominator.
00099 ;
00100 ;
0080 3010      00101 setup   movlw   .16           ; for 16 shifts
0081 00A8      00102         movwf   temp
0082 0823      00103         movf    ACcBHI,W       ;move ACcB to ACcD
0083 00A7      00104         movwf   ACcDHI
0084 0822      00105         movf    ACcBLO,W
0085 00A6      00106         movwf   ACcDLO
0086 01A3      00107         clrf    ACcBHI
0087 01A2      00108         clrf    ACcBLO
0088 3400      00109         retlw   0
00110 ;
00111 ;*****
00112 ;
0089 09A0      00113 neg_A   comf    ACcALO, F       ; negate ACcA ( -ACcA -> ACcA )
008A 0AA0      00114         incf    ACcALO, F
008B 1903      00115         btfsc  STATUS,Z
008C 03A1      00116         decf    ACcAHI, F
008D 09A1      00117         comf    ACcAHI, F
008E 3400      00118         retlw   0
00119 ;
00120 ;*****
00121 ;
00122 ;
008F          00123 D_divF
00124 ;
00125         IF    SIGNED
00126         CALL   S_SIGN
00127         ENDIF
00128 ;
008F 2080      00129         call   setup
0090 01A5      00130         clrf    ACcCHI
0091 01A4      00131         clrf    ACcCLO
00132 ;
00133 ; use the mulMac macro 16 times
00134 ;
00135         divMac
0000         M          LOCAL  NOCHK
0000         M          LOCAL  NOGO
0000         M ;
0092 1003      M          bcf    STATUS,C
0093 0DA6      M          rlf    ACcDLO, F
0094 0DA7      M          rlf    ACcDHI, F
0095 0DA4      M          rlf    ACcCLO, F
0096 0DA5      M          rlf    ACcCHI, F
0097 0821      M          movf   ACcAHI,W
0098 0225      M          subwf  ACcCHI,W       ;check if a>c
0099 1D03      M          btfss  STATUS,Z
009A 289D      M          goto   NOCHK
009B 0820      M          movf   ACcALO,W
009C 0224      M          subwf  ACcCLO,W       ;if msb equal then check lsb
009D 1C03      M NOCHK   btfss  STATUS,C       ;carry set if c>a
009E 28A6      M          goto   NOGO
009F 0820      M          movf   ACcALO,W       ;c-a into c
00A0 02A4      M          subwf  ACcCLO, F
00A1 1C03      M          btfss  STATUS,C
00A2 03A5      M          decf   ACcCHI, F
00A3 0821      M          movf   ACcAHI,W
00A4 02A5      M          subwf  ACcCHI, F
00A5 1403      M          bsf    STATUS,C       ;shift a 1 into b (result)
00A6 0DA2      M NOGO   rlf    ACcBLO, F
00A7 0DA3      M          rlf    ACcBHI, F
0000         M ;

```

AN597

```

00136      divMac
0000      M      LOCAL  NOCHK
0000      M      LOCAL  NOGO
          M ;
00A8 1003 M      bcf     STATUS,C
00A9 0DA6 M      rlf     ACCdLO, F
00AA 0DA7 M      rlf     ACCdHI, F
00AB 0DA4 M      rlf     ACCcLO, F
00AC 0DA5 M      rlf     ACCcHI, F
00AD 0821 M      movf    ACCaHI,W
00AE 0225 M      subwf   ACCcHI,W      ;check if a>c
00AF 1D03 M      btfss   STATUS,Z
00B0 28B3 M      goto    NOCHK
00B1 0820 M      movf    ACCaLO,W
00B2 0224 M      subwf   ACCcLO,W      ;if msb equal then check lsb
00B3 1C03 M NOCHK btfss   STATUS,C      ;carry set if c>a
00B4 28BC M      goto    NOGO
00B5 0820 M      movf    ACCaLO,W      ;c-a into c
00B6 02A4 M      subwf   ACCcLO, F
00B7 1C03 M      btfss   STATUS,C
00B8 03A5 M      decf    ACCcHI, F
00B9 0821 M      movf    ACCaHI,W
00BA 02A5 M      subwf   ACCcHI, F
00BB 1403 M      bsf     STATUS,C      ;shift a 1 into b (result)
00BC 0DA2 M NOGO  rlf     ACCbLO, F
00BD 0DA3 M      rlf     ACCbHI, F
          M ;
00137      divMac
0000      M      LOCAL  NOCHK
0000      M      LOCAL  NOGO
          M ;
00BE 1003 M      bcf     STATUS,C
00BF 0DA6 M      rlf     ACCdLO, F
00C0 0DA7 M      rlf     ACCdHI, F
00C1 0DA4 M      rlf     ACCcLO, F
00C2 0DA5 M      rlf     ACCcHI, F
00C3 0821 M      movf    ACCaHI,W
00C4 0225 M      subwf   ACCcHI,W      ;check if a>c
00C5 1D03 M      btfss   STATUS,Z
00C6 28C9 M      goto    NOCHK
00C7 0820 M      movf    ACCaLO,W
00C8 0224 M      subwf   ACCcLO,W      ;if msb equal then check lsb
00C9 1C03 M NOCHK btfss   STATUS,C      ;carry set if c>a
00CA 28D2 M      goto    NOGO
00CB 0820 M      movf    ACCaLO,W      ;c-a into c
00CC 02A4 M      subwf   ACCcLO, F
00CD 1C03 M      btfss   STATUS,C
00CE 03A5 M      decf    ACCcHI, F
00CF 0821 M      movf    ACCaHI,W
00D0 02A5 M      subwf   ACCcHI, F
00D1 1403 M      bsf     STATUS,C      ;shift a 1 into b (result)
00D2 0DA2 M NOGO  rlf     ACCbLO, F
00D3 0DA3 M      rlf     ACCbHI, F
          M ;
00138      divMac
0000      M      LOCAL  NOCHK
0000      M      LOCAL  NOGO
          M ;
00D4 1003 M      bcf     STATUS,C
00D5 0DA6 M      rlf     ACCdLO, F
00D6 0DA7 M      rlf     ACCdHI, F
00D7 0DA4 M      rlf     ACCcLO, F
00D8 0DA5 M      rlf     ACCcHI, F
00D9 0821 M      movf    ACCaHI,W
00DA 0225 M      subwf   ACCcHI,W      ;check if a>c
00DB 1D03 M      btfss   STATUS,Z
00DC 28DF M      goto    NOCHK

```

```

00DD 0820      M      movf   ACCaLO,W
00DE 0224      M      subwf  ACCcLO,W      ;if msb equal then check lsb
00DF 1C03      M NOCHK  btfss  STATUS,C      ;carry set if c>a
00E0 28E8      M      goto   NOGO
00E1 0820      M      movf   ACCaLO,W      ;c-a into c
00E2 02A4      M      subwf  ACCcLO, F
00E3 1C03      M      btfss  STATUS,C
00E4 03A5      M      decf   ACCcHI, F
00E5 0821      M      movf   ACCaHI,W
00E6 02A5      M      subwf  ACCcHI, F
00E7 1403      M      bsf    STATUS,C      ;shift a 1 into b (result)
00E8 0DA2      M NOGO   rlf    ACCbLO, F
00E9 0DA3      M      rlf    ACCbHI, F
              M ;
00139         divMac
0000          M      LOCAL  NOCHK
0000          M      LOCAL  NOGO
              M ;
00EA 1003      M      bcf    STATUS,C
00EB 0DA6      M      rlf    ACCdLO, F
00EC 0DA7      M      rlf    ACCdHI, F
00ED 0DA4      M      rlf    ACCcLO, F
00EE 0DA5      M      rlf    ACCcHI, F
00EF 0821      M      movf   ACCaHI,W
00F0 0225      M      subwf  ACCcHI,W      ;check if a>c
00F1 1D03      M      btfss  STATUS,Z
00F2 28F5      M      goto   NOCHK
00F3 0820      M      movf   ACCaLO,W
00F4 0224      M      subwf  ACCcLO,W      ;if msb equal then check lsb
00F5 1C03      M NOCHK  btfss  STATUS,C      ;carry set if c>a
00F6 28FE      M      goto   NOGO
00F7 0820      M      movf   ACCaLO,W      ;c-a into c
00F8 02A4      M      subwf  ACCcLO, F
00F9 1C03      M      btfss  STATUS,C
00FA 03A5      M      decf   ACCcHI, F
00FB 0821      M      movf   ACCaHI,W
00FC 02A5      M      subwf  ACCcHI, F
00FD 1403      M      bsf    STATUS,C      ;shift a 1 into b (result)
00FE 0DA2      M NOGO   rlf    ACCbLO, F
00FF 0DA3      M      rlf    ACCbHI, F
              M ;
00140         divMac
0000          M      LOCAL  NOCHK
0000          M      LOCAL  NOGO
              M ;
0100 1003      M      bcf    STATUS,C
0101 0DA6      M      rlf    ACCdLO, F
0102 0DA7      M      rlf    ACCdHI, F
0103 0DA4      M      rlf    ACCcLO, F
0104 0DA5      M      rlf    ACCcHI, F
0105 0821      M      movf   ACCaHI,W
0106 0225      M      subwf  ACCcHI,W      ;check if a>c
0107 1D03      M      btfss  STATUS,Z
0108 290B      M      goto   NOCHK
0109 0820      M      movf   ACCaLO,W
010A 0224      M      subwf  ACCcLO,W      ;if msb equal then check lsb
010B 1C03      M NOCHK  btfss  STATUS,C      ;carry set if c>a
010C 2914      M      goto   NOGO
010D 0820      M      movf   ACCaLO,W      ;c-a into c
010E 02A4      M      subwf  ACCcLO, F
010F 1C03      M      btfss  STATUS,C
0110 03A5      M      decf   ACCcHI, F
0111 0821      M      movf   ACCaHI,W
0112 02A5      M      subwf  ACCcHI, F
0113 1403      M      bsf    STATUS,C      ;shift a 1 into b (result)
0114 0DA2      M NOGO   rlf    ACCbLO, F
0115 0DA3      M      rlf    ACCbHI, F

```

AN597

```

M ;
0000      00141      divMac
0000      M          LOCAL  NOCHK
M          LOCAL  NOGO
M ;
0116 1003      M          bcf    STATUS,C
0117 ODA6      M          rlf    ACCdLO, F
0118 ODA7      M          rlf    ACCdHI, F
0119 ODA4      M          rlf    ACCcLO, F
011A ODA5      M          rlf    ACCcHI, F
011B 0821      M          movf   ACCaHI,W
011C 0225      M          subwf  ACCcHI,W      ;check if a>c
011D 1D03      M          btfss  STATUS,Z
011E 2921      M          goto   NOCHK
011F 0820      M          movf   ACCaLO,W
0120 0224      M          subwf  ACCcLO,W      ;if msb equal then check lsb
0121 1C03      M NOCHK   btfss  STATUS,C      ;carry set if c>a
0122 292A      M          goto   NOGO
0123 0820      M          movf   ACCaLO,W      ;c-a into c
0124 02A4      M          subwf  ACCcLO, F
0125 1C03      M          btfss  STATUS,C
0126 03A5      M          decf   ACCcHI, F
0127 0821      M          movf   ACCaHI,W
0128 02A5      M          subwf  ACCcHI, F
0129 1403      M          bsf    STATUS,C      ;shift a 1 into b (result)
012A ODA2      M NOGO    rlf    ACCbLO, F
012B ODA3      M          rlf    ACCbHI, F
M ;
0000      00142      divMac
0000      M          LOCAL  NOCHK
M          LOCAL  NOGO
M ;
012C 1003      M          bcf    STATUS,C
012D ODA6      M          rlf    ACCdLO, F
012E ODA7      M          rlf    ACCdHI, F
012F ODA4      M          rlf    ACCcLO, F
0130 ODA5      M          rlf    ACCcHI, F
0131 0821      M          movf   ACCaHI,W
0132 0225      M          subwf  ACCcHI,W      ;check if a>c
0133 1D03      M          btfss  STATUS,Z
0134 2937      M          goto   NOCHK
0135 0820      M          movf   ACCaLO,W
0136 0224      M          subwf  ACCcLO,W      ;if msb equal then check lsb
0137 1C03      M NOCHK   btfss  STATUS,C      ;carry set if c>a
0138 2940      M          goto   NOGO
0139 0820      M          movf   ACCaLO,W      ;c-a into c
013A 02A4      M          subwf  ACCcLO, F
013B 1C03      M          btfss  STATUS,C
013C 03A5      M          decf   ACCcHI, F
013D 0821      M          movf   ACCaHI,W
013E 02A5      M          subwf  ACCcHI, F
013F 1403      M          bsf    STATUS,C      ;shift a 1 into b (result)
0140 ODA2      M NOGO    rlf    ACCbLO, F
0141 ODA3      M          rlf    ACCbHI, F
M ;
0000      00143      divMac
0000      M          LOCAL  NOCHK
M          LOCAL  NOGO
M ;
0142 1003      M          bcf    STATUS,C
0143 ODA6      M          rlf    ACCdLO, F
0144 ODA7      M          rlf    ACCdHI, F
0145 ODA4      M          rlf    ACCcLO, F
0146 ODA5      M          rlf    ACCcHI, F
0147 0821      M          movf   ACCaHI,W
0148 0225      M          subwf  ACCcHI,W      ;check if a>c
0149 1D03      M          btfss  STATUS,Z

```

```

014A 294D      M      goto      NOCHK
014B 0820      M      movf      ACCaLO,W
014C 0224      M      subwf     ACCcLO,W      ;if msb equal then check lsb
014D 1C03      M NOCHK   btfss     STATUS,C      ;carry set if c>a
014E 2956      M      goto      NOGO
014F 0820      M      movf      ACCaLO,W      ;c-a into c
0150 02A4      M      subwf     ACCcLO, F
0151 1C03      M      btfss     STATUS,C
0152 03A5      M      decf      ACCcHI, F
0153 0821      M      movf      ACCaHI,W
0154 02A5      M      subwf     ACCcHI, F
0155 1403      M      bsf       STATUS,C      ;shift a 1 into b (result)
0156 0DA2      M NOGO   rlf       ACCbLO, F
0157 0DA3      M      rlf       ACCbHI, F
M ;
00144         divMac
0000          M      LOCAL  NOCHK
0000          M      LOCAL  NOGO
M ;
0158 1003      M      bcf       STATUS,C
0159 0DA6      M      rlf       ACCdLO, F
015A 0DA7      M      rlf       ACCdHI, F
015B 0DA4      M      rlf       ACCcLO, F
015C 0DA5      M      rlf       ACCcHI, F
015D 0821      M      movf     ACCaHI,W
015E 0225      M      subwf     ACCcHI,W      ;check if a>c
015F 1D03      M      btfss     STATUS,Z
0160 2963      M      goto      NOCHK
0161 0820      M      movf     ACCaLO,W
0162 0224      M      subwf     ACCcLO,W      ;if msb equal then check lsb
0163 1C03      M NOCHK   btfss     STATUS,C      ;carry set if c>a
0164 296C      M      goto      NOGO
0165 0820      M      movf     ACCaLO,W      ;c-a into c
0166 02A4      M      subwf     ACCcLO, F
0167 1C03      M      btfss     STATUS,C
0168 03A5      M      decf     ACCcHI, F
0169 0821      M      movf     ACCaHI,W
016A 02A5      M      subwf     ACCcHI, F
016B 1403      M      bsf       STATUS,C      ;shift a 1 into b (result)
016C 0DA2      M NOGO   rlf       ACCbLO, F
016D 0DA3      M      rlf       ACCbHI, F
M ;
00145         divMac
0000          M      LOCAL  NOCHK
0000          M      LOCAL  NOGO
M ;
016E 1003      M      bcf       STATUS,C
016F 0DA6      M      rlf       ACCdLO, F
0170 0DA7      M      rlf       ACCdHI, F
0171 0DA4      M      rlf       ACCcLO, F
0172 0DA5      M      rlf       ACCcHI, F
0173 0821      M      movf     ACCaHI,W
0174 0225      M      subwf     ACCcHI,W      ;check if a>c
0175 1D03      M      btfss     STATUS,Z
0176 2979      M      goto      NOCHK
0177 0820      M      movf     ACCaLO,W
0178 0224      M      subwf     ACCcLO,W      ;if msb equal then check lsb
0179 1C03      M NOCHK   btfss     STATUS,C      ;carry set if c>a
017A 2982      M      goto      NOGO
017B 0820      M      movf     ACCaLO,W      ;c-a into c
017C 02A4      M      subwf     ACCcLO, F
017D 1C03      M      btfss     STATUS,C
017E 03A5      M      decf     ACCcHI, F
017F 0821      M      movf     ACCaHI,W
0180 02A5      M      subwf     ACCcHI, F
0181 1403      M      bsf       STATUS,C      ;shift a 1 into b (result)
0182 0DA2      M NOGO   rlf       ACCbLO, F

```

AN597

```
0183 ODA3          M      rlf      ACCbHI, F
                   M ;
00146              divMac
0000              M      LOCAL  NOCHK
0000              M      LOCAL  NOGO
                   M ;
0184 1003         M      bcf      STATUS,C
0185 ODA6         M      rlf      ACCdLO, F
0186 ODA7         M      rlf      ACCdHI, F
0187 ODA4         M      rlf      ACCcLO, F
0188 ODA5         M      rlf      ACCcHI, F
0189 0821         M      movf     ACCaHI,W
018A 0225         M      subwf    ACCcHI,W      ;check if a>c
018B 1D03         M      btfss   STATUS,Z
018C 298F         M      goto     NOCHK
018D 0820         M      movf     ACCaLO,W
018E 0224         M      subwf    ACCcLO,W      ;if msb equal then check lsb
018F 1C03         M NOCHK    btfss   STATUS,C      ;carry set if c>a
0190 2998         M      goto     NOGO
0191 0820         M      movf     ACCaLO,W      ;c-a into c
0192 02A4         M      subwf    ACCcLO, F
0193 1C03         M      btfss   STATUS,C
0194 03A5         M      decf     ACCcHI, F
0195 0821         M      movf     ACCaHI,W
0196 02A5         M      subwf    ACCcHI, F
0197 1403         M      bsf      STATUS,C      ;shift a 1 into b (result)
0198 ODA2         M NOGO    rlf      ACCbLO, F
0199 ODA3         M      rlf      ACCbHI, F
                   M ;
00147              divMac
0000              M      LOCAL  NOCHK
0000              M      LOCAL  NOGO
                   M ;
019A 1003         M      bcf      STATUS,C
019B ODA6         M      rlf      ACCdLO, F
019C ODA7         M      rlf      ACCdHI, F
019D ODA4         M      rlf      ACCcLO, F
019E ODA5         M      rlf      ACCcHI, F
019F 0821         M      movf     ACCaHI,W
01A0 0225         M      subwf    ACCcHI,W      ;check if a>c
01A1 1D03         M      btfss   STAUS,Z
01A2 29A5         M      goto     NOCHK
01A3 0820         M      movf     ACCaLO,W
01A4 0224         M      subwf    ACCcLO,W      ;if msb equal then check lsb
01A5 1C03         M NOCHK    btfss   STAUS,C      ;carry set if c>a
01A6 29AE         M      goto     NOGO
01A7 0820         M      movf     ACCaLO,W      ;c-a into c
01A8 02A4         M      subwf    ACCcLO, F
01A9 1C03         M      btfss   STAUS,C
01AA 03A5         M      decf     ACCHI, F
01AB 0821         M      movf     ACCaHI,W
01AC 02A5         M      subwf    ACCHI, F
01AD 1403         M      bsf      STAUS,C      ;shift a 1 into b (result)
01AE ODA2         M NOGO    rlf      ACCbLO, F
01AF ODA3         M      rlf      ACCbHI, F
                   M ;
00148              divMac
0000              M      LOCAL  NOCHK
0000              M      LOCAL  NOGO
                   M ;
01B0 1003         M      bcf      STATUS,C
01B1 ODA6         M      rlf      ACCdLO, F
01B2 ODA7         M      rlf      ACCcHI, F
01B3 ODA4         M      rlf      ACCcLO, F
01B4 ODA5         M      rlf      ACCcHI, F
01B5 0821         M      movf     ACCaHI,W
```

```

01B6 0225      M      subwf  ACCHI,W      ;check if a>c
01B7 1D03      M      btfss  STATUS,Z
01B8 29BB      M      goto   NOCHK
01B9 0820      M      movf   ACCaLO,W
01BA 0224      M      subwf  ACCcLO,W      ;if msb equal then check lsb
01BB 1C03      M NOCHK  btfss  STATUS,C      ;carry set if c>a
01BC 29C4      M      goto   NOGO
01BD 0820      M      movf   ACCaLO,W      ;c-a into c
01BE 02A4      M      subwf  ACCcLO, F
01BF 1C03      M      btfss  STATUS,C
01C0 03A5      M      decf   ACCcHI, F
01C1 0821      M      movf   ACCaHI,W
01C2 02A5      M      subwf  ACCcHI, F
01C3 1403      M      bsf   STATUS,C      ;shift a 1 into b (result)
01C4 0DA2      M NOGO  rlf   ACCbLO, F
01C5 0DA3      M      rlf   ACCbHI, F
M ;
00149          divMac
0000          M      LOCAL NOCHK
0000          M      LOCAL NOGO
M ;
01C6 1003      M      bcf   STATUS,C
01C7 0DA6      M      rlf   ACCdLO, F
01C8 0DA7      M      rlf   ACCdHI, F
01C9 0DA4      M      rlf   ACCcLO, F
01CA 0DA5      M      rlf   ACCcHI, F
01CB 0821      M      movf   ACCaHI,W
01CC 0225      M      subwf  ACCcHI,W      ;check if a>c
01CD 1D03      M      btfss  STATUS,Z
01CE 29D1      M      goto   NOCHK
01CF 0820      M      movf   ACCaLO,W
01D0 0224      M      subwf  ACCcLO,W      ;if msb equal then check lsb
01D1 1C03      M NOCHK  btfss  STATUS,C      ;carry set if c>a
01D2 29DA      M      goto   NOGO
01D3 0820      M      movf   ACCaLO,W      ;c-a into c
01D4 02A4      M      subwf  ACCcLO, F
01D5 1C03      M      btfss  STATUS,C
01D6 03A5      M      decf   ACCcHI, F
01D7 0821      M      movf   ACCaHI,W
01D8 02A5      M      subwf  ACCcHI, F
01D9 1403      M      bsf   STATUS,C      ;shift a 1 into b (result)
01DA 0DA2      M NOGO  rlf   ACCbLO, F
01DB 0DA3      M      rlf   ACCbHI, F
M ;
00150          divMac
0000          M      LOCAL NOCHK
0000          M      LOCAL NOGO
M ;
01DC 1003      M      bcf   STATUS,C
01DD 0DA6      M      rlf   ACCdLO, F
01DE 0DA7      M      rlf   ACCdHI, F
01DF 0DA4      M      rlf   ACCcLO, F
01E0 0DA5      M      rlf   ACCcHI, F
01E1 0821      M      movf   ACCaHI,W
01E2 0225      M      subwf  ACCcHI,W      ;check if a>c
01E3 1D03      M      btfss  STATUS,Z
01E4 29E7      M      goto   NOCHK
01E5 0820      M      movf   ACCaLO,W
01E6 0224      M      subwf  ACCcLO,W      ;if msb equal then check lsb
01E7 1C03      M NOCHK  btfss  STATUS,C      ;carry set if c>a
01E8 29F0      M      goto   NOGO
01E9 0820      M      movf   ACCaLO,W      ;c-a into c
01EA 02A4      M      subwf  ACCcLO, F
01EB 1C03      M      btfss  STATUS,C
01EC 03A5      M      decf   ACCcHI, F
01ED 0821      M      movf   ACCaHI,W
01EE 02A5      M      subwf  ACCcHI, F

```

AN597

```
01EF 1403          M          bsf      STATUS,C          ;shift a 1 into b (result)
01F0 0DA2          M NOGO    rlf      ACCbLO, F
01F1 0DA3          M          rlf      ACCbHI, F
                  M ;
00151 ;
00152          IF      SIGNED
00153              btfss   sign,MSB          ; check sign if negative
00154              retlw   0
00155              goto    neg_B            ; negate ACCa ( -ACCa -> ACCa )
00156          ELSE
01F2 3400          00157              retlw   0
00158          ENDIF
00159 ;
00160 ;*****
00161 ; Assemble this section only if Signed Arithmetic Needed
00162 ;
00163          IF      SIGNED
00164 ;
00165 S_SIGN      movf     ACCaHI,W
00166              xorwf   ACCbHI,W
00167              movwf   sign
00168              btfss   ACCbHI,MSB        ; if MSB set go & negate ACCb
00169              goto    chek_A
00170 ;
00171              comf    ACCbLO, F          ; negate ACCb
00172              incf    ACCbLO, F
00173              btfsc   STATUS,Z
00174              decf    ACCbHI, F
00175              comf    ACCbHI, F
00176 ;
00177 chek_A      btfss   ACCaHI,MSB        ; if MSB set go & negate ACCa
00178              retlw   0
00179              goto    neg_A
00180 ;
00181          ENDIF
00182 ;
00183 ;
00184 ;
00185          ifdef XDCR
00186 ;
00187 ; This file has been included, do not have test program.
00188 ;
00189          else
00190 ;
00191 ;*****
00192 ;                      Test Program
00193 ;*****
00194 ;      Load constant values to ACCa & ACCb for testing
00195 ;
00196 main      movlw   1
00197              movwf   ACCaHI
00198              movlw   0FF          ; loads ACCa = 01FF
00199              movwf   ACCaLO
00200 ;
00201              movlw   07F
00202              movwf   ACCbHI
00203              movlw   0FF          ; loads ACCb = 7FFF
00204              movwf   ACCbLO
00205 ;
00206              call    D_divF          ; remainder in ACCc. Here ACCb =0040 &
00207              ; ACCc=003F
00208 self      goto    self
00209 ;
00210 ;          org      PIC54
00211 ;          LIST     p=16c54
00212 ;          goto     main
00213 ;*****
```



```
00214 ;
00215
00216     endif
00217 ;
00218 ;     END ; END directive MUST be commented out if this file is included.
00129     LIST
00130
00158     LIST
00159
00160     end
```

MPASM 01.40 Released XDCR.ASM 1-22-1997 10:55:26 PAGE 15
MEMORY USAGE MAP ('X' = Used, '-' = Unused)

```
0000 : XXXXXXXXXXXXXXXXXXXX XXXXXXXXXXXXXXXXXXXX XXXXXXXXXXXXXXXXXXXX XXXXXXXXXXXX-----
0080 : XXXXXXXXXXXXXXXXXXXX XXXXXXXXXXXXXXXXXXXX XXXXXXXXXXXXXXXXXXXX XXXXXXXXXXXXXXXXXXXX
00C0 : XXXXXXXXXXXXXXXXXXXX XXXXXXXXXXXXXXXXXXXX XXXXXXXXXXXXXXXXXXXX XXXXXXXXXXXXXXXXXXXX
0100 : XXXXXXXXXXXXXXXXXXXX XXXXXXXXXXXXXXXXXXXX XXXXXXXXXXXXXXXXXXXX XXXXXXXXXXXXXXXXXXXX
0140 : XXXXXXXXXXXXXXXXXXXX XXXXXXXXXXXXXXXXXXXX XXXXXXXXXXXXXXXXXXXX XXXXXXXXXXXXXXXXXXXX
0180 : XXXXXXXXXXXXXXXXXXXX XXXXXXXXXXXXXXXXXXXX XXXXXXXXXXXXXXXXXXXX XXXXXXXXXXXXXXXXXXXX
01C0 : XXXXXXXXXXXXXXXXXXXX XXXXXXXXXXXXXXXXXXXX XXXXXXXXXXXXXXXXXXXX XXXXXXXXXXXXXXXXXXXX
0200 : XXXXXX-----
```

All other memory blocks unused.

Program Memory Words Used: 448
Program Memory Words Free: 3648

Errors : 0
Warnings : 0 reported, 0 suppressed
Messages : 7 reported, 0 suppressed

WORLDWIDE SALES & SERVICE

AMERICAS

Corporate Office

Microchip Technology Inc.
2355 West Chandler Blvd.
Chandler, AZ 85224-6199
Tel: 602-786-7200 Fax: 602-786-7277
Technical Support: 602 786-7627
Web: <http://www.microchip.com>

Atlanta

Microchip Technology Inc.
500 Sugar Mill Road, Suite 200B
Atlanta, GA 30350
Tel: 770-640-0034 Fax: 770-640-0307

Boston

Microchip Technology Inc.
5 Mount Royal Avenue
Marlborough, MA 01752
Tel: 508-480-9990 Fax: 508-480-8575

Chicago

Microchip Technology Inc.
333 Pierce Road, Suite 180
Itasca, IL 60143
Tel: 630-285-0071 Fax: 630-285-0075

Dallas

Microchip Technology Inc.
14651 Dallas Parkway, Suite 816
Dallas, TX 75240-8809
Tel: 972-991-7177 Fax: 972-991-8588

Dayton

Microchip Technology Inc.
Two Prestige Place, Suite 150
Miamisburg, OH 45342
Tel: 937-291-1654 Fax: 937-291-9175

Los Angeles

Microchip Technology Inc.
18201 Von Karman, Suite 1090
Irvine, CA 92612
Tel: 714-263-1888 Fax: 714-263-1338

New York

Microchip Technology Inc.
150 Motor Parkway, Suite 416
Hauppauge, NY 11788
Tel: 516-273-5305 Fax: 516-273-5335

San Jose

Microchip Technology Inc.
2107 North First Street, Suite 590
San Jose, CA 95131
Tel: 408-436-7950 Fax: 408-436-7955

Toronto

Microchip Technology Inc.
5925 Airport Road, Suite 200
Mississauga, Ontario L4V 1W1, Canada
Tel: 905-405-6279 Fax: 905-405-6253

ASIA/PACIFIC

Hong Kong

Microchip Asia Pacific
RM 3801B, Tower Two
Metroplaza
223 Hing Fong Road
Kwai Fong, N.T., Hong Kong
Tel: 852-2-401-1200 Fax: 852-2-401-3431

India

Microchip Technology India
No. 6, Legacy, Convent Road
Bangalore 560 025, India
Tel: 91-80-229-0061 Fax: 91-80-229-0062

Korea

Microchip Technology Korea
168-1, Youngbo Bldg. 3 Floor
Samsung-Dong, Kangnam-Ku
Seoul, Korea
Tel: 82-2-554-7200 Fax: 82-2-558-5934

Shanghai

Microchip Technology
RM 406 Shanghai Golden Bridge Bldg.
2077 Yan'an Road West, Hongjiao District
Shanghai, PRC 200335
Tel: 86-21-6275-5700
Fax: 86 21-6275-5060

Singapore

Microchip Technology Taiwan
Singapore Branch
200 Middle Road
#10-03 Prime Centre
Singapore 188980
Tel: 65-334-8870 Fax: 65-334-8850

Taiwan, R.O.C

Microchip Technology Taiwan
10F-1C 207
Tung Hua North Road
Taipei, Taiwan, ROC
Tel: 886 2-717-7175 Fax: 886-2-545-0139

EUROPE

United Kingdom

Arizona Microchip Technology Ltd.
Unit 6, The Courtyard
Meadow Bank, Furlong Road
Bourne End, Buckinghamshire SL8 5AJ
Tel: 44-1628-851077 Fax: 44-1628-850259

France

Arizona Microchip Technology SARL
Zone Industrielle de la Bonde
2 Rue du Buisson aux Fraises
91300 Massy, France
Tel: 33-1-69-53-63-20 Fax: 33-1-69-30-90-79

Germany

Arizona Microchip Technology GmbH
Gustav-Heinemann-Ring 125
D-81739 München, Germany
Tel: 49-89-627-144 0 Fax: 49-89-627-144-44

Italy

Arizona Microchip Technology SRL
Centro Direzionale Colleone
Palazzo Taurus 1 V. Le Colleoni 1
20041 Agrate Brianza
Milan, Italy
Tel: 39-39-6899939 Fax: 39-39-6899883

JAPAN

Microchip Technology Intl. Inc.
Benex S-1 6F
3-18-20, Shin Yokohama
Kohoku-Ku, Yokohama
Kanagawa 222 Japan
Tel: 81-4-5471- 6166 Fax: 81-4-5471-6122

5/8/97



MICROCHIP

All rights reserved. © 1997, Microchip Technology Incorporated, USA. 6/97

Information contained in this publication regarding device applications and the like is intended for suggestion only and may be superseded by updates. No representation or warranty is given and no liability is assumed by Microchip Technology Incorporated with respect to the accuracy or use of such information, or infringement of patents or other intellectual property rights arising from such use or otherwise. Use of Microchip's products as critical components in life support systems is not authorized except with express written approval by Microchip. No licenses are conveyed, implicitly or otherwise, under any intellectual property rights. The Microchip logo and name are registered trademarks of Microchip Technology Inc. in the U.S.A. and other countries. All rights reserved. All other trademarks mentioned herein are the property of their respective companies.