

INSTALLATION AND OPERATING INSTRUCTIONS

MODEL KBSI-240D

Signal Isolator KB Part No. 9431



See Safety Warning on Page 1

The information contained in this manual is intended to be accurate. However, the Manufacturer retains the right to make changes in design which may not be included herein.

PENTA  **POWER**

III. WIRING.



Warning! Read Safety Warning on page 1 before attempting to use this control.

Warning! To avoid erratic operation do not bundle AC Line and motor wires with potentiometer, voltage following, enable, inhibit or other signal wiring. Use shielded cables on all signal wiring over 12" (30 cm) – Earth ground the shield on the drive side only.

- A.** AC Power – The KBSI-240D is powered with either 115 or 230V AC, 50/60 Hz by arranging the jumpers between terminals “1” to “4” properly. See figures 2A and 2B. Be sure unit is wired in accordance with the National Electric Code and other codes that may apply. It is recommended that a 1 amp fuse be installed in series with the AC line.
- B.** Input Terminals – A voltage or current signal from a microprocessor, tachometer, transducer, etc. is to be connected to terminals “5” through “8.” The selection of the proper terminal is based on the maximum level of the input signal. See figures 3 and 4.

FIGURE 2A – 115V CONNECTION

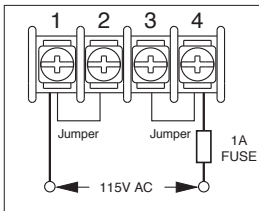
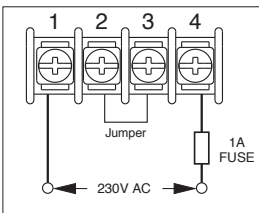

FIGURE 2B – 230V CONNECTION



i. Current Signal Input



Warning! Read Safety Warning on Page 1 before attempting to use this control.

The Signal Isolator accepts 4 – 20 mA DC input to provide 0 – 9 Volts DC output. Connect the current signal input common (–) to Terminal “5” and the positive (+) to Terminal “6”, as shown in Figure 3. Other current signal input ranges can also be used, as described below. Calibrate the Signal Isolator, as described below.

Note: Two resistors, for 10 – 50 mA and 1 – 5 mA inputs, are supplied in the hardware bag included with this kit.

4 – 20 DC Signal Input: No resistor required. Set Jumper J1 in “CUR” position.

10 – 50 mA DC Signal Input (Use Large Resistor with Color Code

“Brown–Green–Brown”): Install the 150Ω – 1W resistor across Terminals

“5” and “6”. Set Jumper J1 in “CUR” position.

1 – 5 mA DC Signal Input (Use Small Resistor with Color Code

“Brown–Black–Red”): Install the 1kΩ – 1/4W resistor across Terminals “5” and “6”. Set Jumper J1 in “VOLT” position.

Procedure to Calibrate the Signal Isolator When Using Current Signal Input:

1. Connect a DC voltmeter (a digital voltmeter is suggested) to Terminals “9” (–) and “10” (+).
2. Apply the minimum signal input current to Terminals “5” (–) and “6” (+).
3. Adjust the MIN Trimpot on the Signal Isolator to obtain an output voltage of 0 Volts DC.
4. Apply the maximum signal input current to Terminals “5” (–) and “6” (+).
5. Adjust the MAX Trimpot on the Signal Isolator to obtain an output voltage of 9 Volts DC.

Notes: 1. To achieve better accuracy, repeat steps 2 – 5. **2.** If other than 0 Volts DC (minimum) and 9 Volts DC (maximum) is desired, use the MIN and MAX Trimpots on the Signal Isolator to adjust the

6 output to the desired voltages in steps 3 and 5.

**FIGURE 3
CURRENT SIGNAL
INPUT CONNECTION**

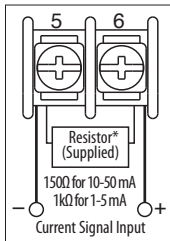

*No resistor required for 4-20 mA.

ii. Voltage Input Signal



Warning! Read Safety Warning on Page 1 before attempting to use this control.

Note: The Voltage/Current (VLT/CUR) jumper must be in the VLT position (factory setting). The KBSI-240D is designed to accept a wide range of input voltage signals as follows:

TABLE 2 – VOLTAGE INPUT SIGNAL

Input Terminals	Minimum Input Voltage Range	Maximum Input Voltage Range
5, 6	0 - 5	0 - 25
5, 7	0 - 25	0 - 120
5, 8	0 - 120	0 - 550

Connect input voltage signal to proper input terminals as indicated in figure 4.

1. Connect a 10V DC meter (digital meter is suggested) to terminals “9” (-) and “10” (+).
2. Apply the maximum input voltage that would be supplied from tach, transducer, etc.
3. Adjust the “MAX” trimpot to the desired output voltage.

Example: A follower motor is to follow the output of a main motor with an armature voltage range of 0 - 90V.

FIGURE 4 – VOLTAGE INPUT SIGNAL CONNECTIONS

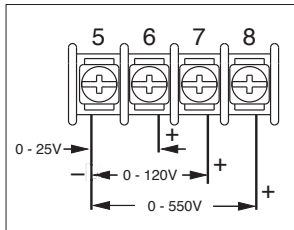

- a) Connect the armature of the main motor to the SI input terminals “5” (-) and “7” (+).
- b) Set the armature voltage of the main motor to zero (0). Adjust the “MIN” trimpot so that the output at terminals “9” and “10” reads zero (0) volts.
- c) Reset the armature voltage of the main motor to 90V. Adjust the “MAX” trimpot so that the output voltage is 9V DC.

Notes:

1. When setting the output voltage using the “MIN” and “MAX” trimpots the voltage or speed of the driven motor can be read directly instead of using the output of the KBSI.
2. When readjusting the “MIN” and “MAX” trimpots, always set the minimum voltage first and then the maximum voltage.
3. Trimpots allow approximately 20 turns for the full range of adjustment. If during the adjustment procedure the output stops changing, try reversing the direction of rotation of trimpot.

IV. OUTPUT SIGNAL

The output signal from the SI is obtained from terminals “9” (-) and “10” (+). Connect the output directly to the signal following input terminal of the speed control. For multiple follower motors, several controls can be driven from a single KBSI-240D. Be sure the AC line connections to the follower control are to the same phase (eg, L1 to L1 and L2 to L2 of all controls.)

The output from the KBSI-240D can be scaled to control the speed control over any desired speed range. Adjust the “MIN” trimpot to provide the desired minimum speed and the “MAX” trimpot to provide the desired maximum speed.

FIGURE 5 – LEADER/MULTIPLE FOLLOWER VOLTAGE FOLLOWING SYSTEM

A) From a Single Main Motor

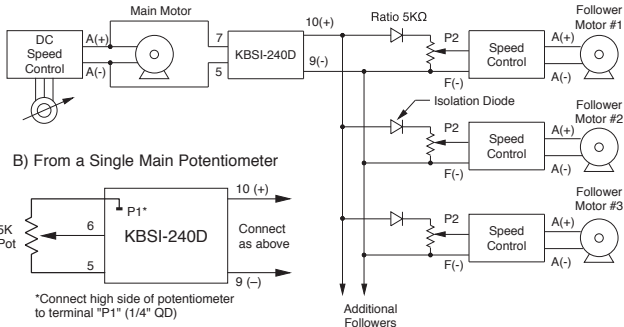

B) From a Single Main Potentiometer

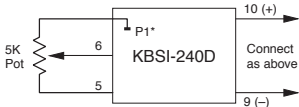

*Connect high side of potentiometer to terminal "P1" (1/4" QD)

A 10K ratio potentiometer is used to control up to ten (10) follower motors.

If a 5K ratio potentiometer is used, up to five (5) follower motors can be controlled.

WARNING! If Signal Isolator is connected to multiple speed controls;

- 1) Multiple controls must be powered from the same phase of AC line.
- 2) The positive input terminal to each speed control must be installed with a 1 amp, 600V (1N4005) isolation diode as shown.
- 3) Multiple speed controls can not be used with PWM, Regenerative or Variable Frequency Drives (Inverters).

FIGURE 6A – LEADER/FOLLOWER VOLTAGE FOLLOWING SYSTEM

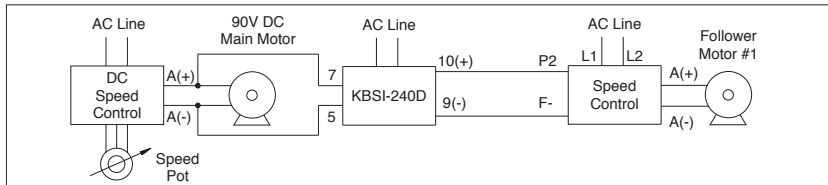

FIGURE 6B – PROCESS CONTROL WITH AUTO/MANUAL SWITCH

The KBSI-240D can be wired in an Auto/Manual mode which will allow manual override of an automatic process. See figure 6B.

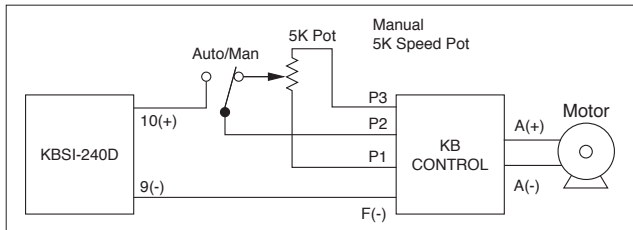

FIGURE 6C – PROCESS CONTROL WITH AUTO (RATIO POT)/MANUAL SWITCH

The following circuit provides for dual purpose usage of the speed pot. In the "AUTO" mode it is used for ratio control and in the "MAN" mode it is used for manual speed adjustment.

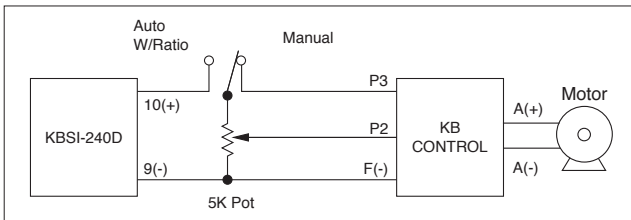
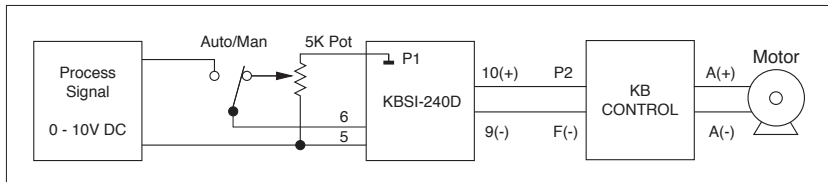

FIGURE 6D – AUTO/MANUAL OPERATION WITH POTENTIOMETER ON KBSI INPUT



Note: The preceding circuit provides for the speed pot to be used in "MAN" mode only. In "AUTO" mode, the process control signal is supplied directly to the signal isolator.

- NOTES -

- NOTES -

V. LIMITED WARRANTY

For a period of 18 months from the date of original purchase, KB Electronics, Inc. will repair or replace, without charge, devices which our examination proves to be defective in material or workmanship. This warranty is valid if the unit has not been tampered with by unauthorized persons, misused, abused, or improperly installed and has been used in accordance with the instructions and/or ratings supplied. The foregoing is in lieu of any other warranty or guarantee, expressed or implied. KB Electronics, Inc. is not responsible for any expense, including installation and removal, inconvenience, or consequential damage, including injury to any person, caused by items of our manufacture or sale. Some states do not allow certain exclusions or limitations found in this warranty and therefore they may not apply to you. In any event, the total liability of KB Electronics, Inc., under any circumstance, shall not exceed the full purchase price of this product.

(Rev 2/2000)



KB Electronics, Inc.

12095 NW 39th Street, Coral Springs, FL 33065-2516 • (954) 346-4900 • Fax (954) 346-3377
Outside Florida Call TOLL FREE (800) 221-6570 • email – info@kbelectronics.com
www.kbelectronics.com

(A40255) – Rev. E – 9/7/2010