

WIRING, GROUNDING, AND SHIELDING TECHNIQUES

Proper wiring, grounding, and shielding techniques are important in obtaining proper servo operation and performance. Incorrect wiring, grounding, or shielding can cause erratic servo performance or even a complete lack of operation. This note summarizes the proper techniques and is intended as a supplement to the information contained in the controller instruction manuals.

MOTOR POWER WIRING

Pacific Scientific motors are three phase and hence have three terminals. These three motor terminals are labeled R, S, and T. It is imperative that the R, S, and T motor terminals be connected to the respective R, S, and T outputs of the controller. Improper phasing of these terminals will result in erratic motor operation including “deadspots,” runaway, or stall.

Another important aspect of motor wiring is grounding of the motor. There is capacitive coupling between the motor’s three phase winding and the motor’s case. When PWM voltages are applied to the motor terminals, the motor case tends to follow these voltages because of the coupling capacitance. If the motor is not grounded, Fig. D-1a, a shock hazard is present because of capacitively coupled voltage on the motor case. Therefore, motor wiring should be viewed as a four wire connection rather than a three wire connection with the fourth wire being motor ground as shown in D-1b. The motor must be properly grounded to insure proper operation and to prevent shock hazard.

When the motor is grounded, pulses of current flow in the ground wire due to the motor’s winding-case capacitance. These pulses are short in duration and occur at the PWM frequency. Electrical noise due to these pulses can be radiated if proper techniques are not used. To prevent radiated noise, the motor ground wire should be tightly bundled or twisted with the three wires connected to the motor terminals as shown in D-1c. This will typically reduce radiated noise to an acceptable level.

If desired or required, two other techniques can be applied to attenuate noise further. Both techniques are shown in D-1d. The first is shielding the four motor wires. The shield should be connected at the controller end only. As a general rule a shield should only be connected at one end to prevent ground loops. The second technique is the insertion of a common mode choke in the three wires connecting the motor terminals to the controller. This common mode choke is simply 10 turns of each motor terminal wire on a Ferroxcube 510-00003-00 ferrite toroidal core. This choke acts to reduce the amplitude of the current pulses flowing in the motor ground wire.

As a general rule, the motor wiring should be kept as far away as possible from the feedback transducer wiring and any other signal level wiring. In addition, all signal level wiring should be done using shielded cable to reduce the risk of noise problems.

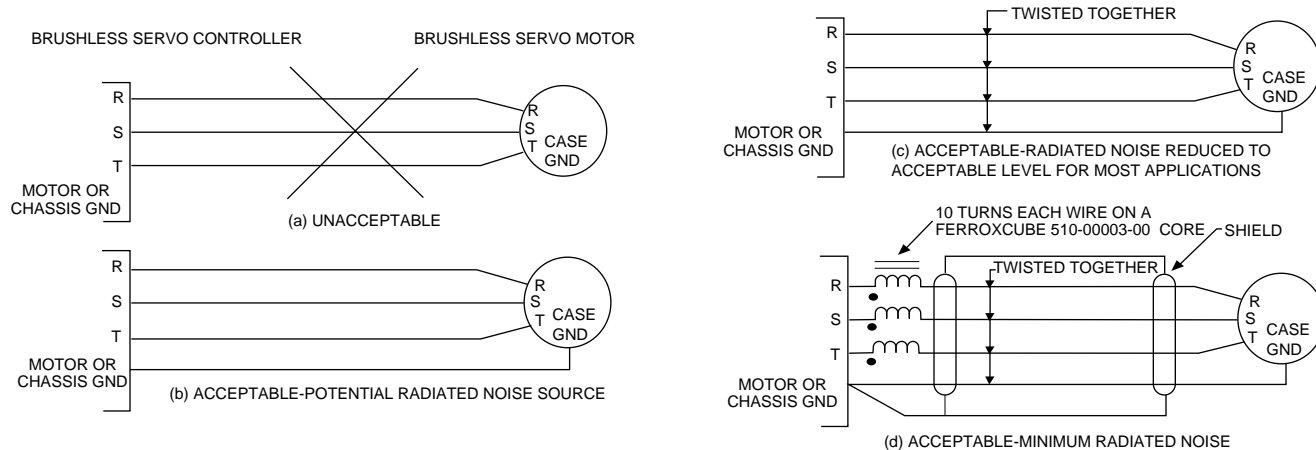

Figure D-1. Motor Wiring

WIRING, GROUNDING, AND SHIELDING TECHNIQUES (Cont.)

FEEDBACK TRANSDUCER WIRING

Pacific Scientific brushless servo systems use three standard feedback devices. For a torque only control system, Hall-effect devices are used. These devices provide motor commutation information to the brushless servo controller. For analog velocity control systems, a Tachsyn® is used. This device provides motor commutation information and motor velocity information. Finally, for position control systems and some velocity control systems a resolver is used. This device provides motor commutation information, motor velocity information, and motor position information.

Each of the feedback devices described above must be properly wired to insure proper operation of the servo system. The wiring practices for each device are described below.

HALL-EFFECT DEVICES

Three Hall-effect devices are required to provide commutation information for Pacific Scientific three-phase brushless servo motors. The Hall-effect outputs are open collector transistors. These outputs drive the brushless servo controller sensor inputs which have resistor pull-ups.

Wiring for the Hall-effect devices consists of one wire for each of the three sensor signals and two wires which provide power to the Hall-effect devices. The three sensor signal wires should be twisted together and the two power wires should be twisted together as shown in D-2a.

For improved noise immunity, the five wires can be placed in a shield which is connected to the 12V RTN at the controller as shown in D-2b. This is especially important if the motor wiring is run near (within 12 inches) of the sensor wiring. The shield should only be connected at the controller end.

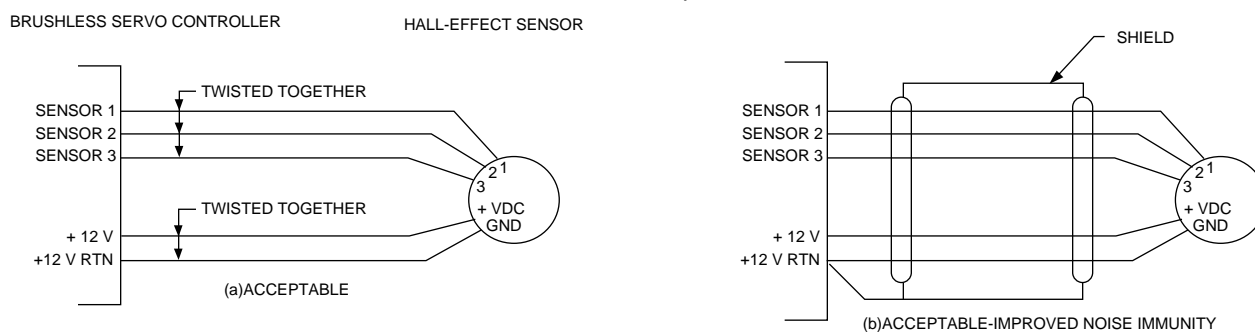

Figure D-2. Hall-Effect Sensor Wiring

TACHSYN® WIRING

The Tachsyn® is a five wire device that operates similar to a resolver. Two of the Tachsyn® wires are a high frequency excitation signal. The remaining three wires are outputs which supply commutation and velocity information to the controller. **Both sets of wires must be shielded and the two excitation wires must be**

in separate shield from the output wires. If they are not placed in separate shields, the motor will not operate or will operate erratically.

The Tachsyn® must always be wired as shown in Figure D-3b. Any other wiring scheme will result in improper motor operation.

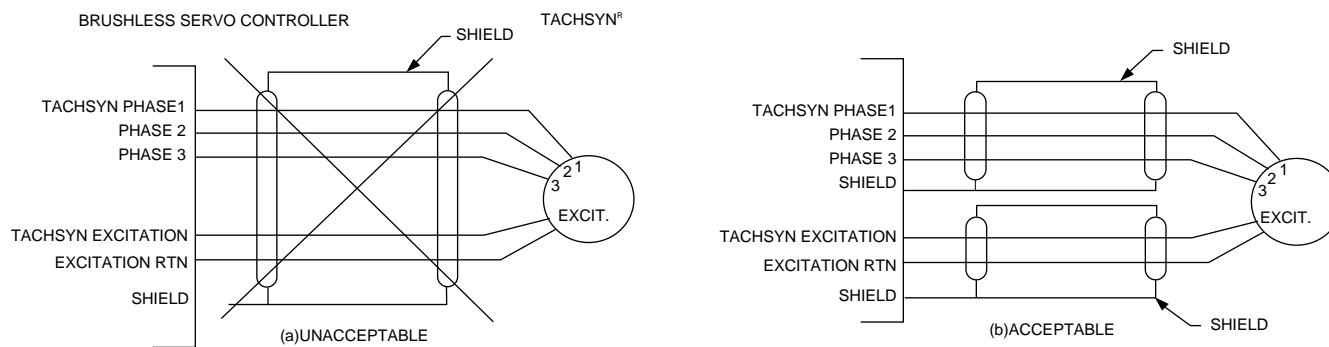

Figure D-3. Tachsyn® Wiring

WIRING, GROUNDING, AND SHIELDING TECHNIQUES (Cont.)

RESOLVER WIRING

The resolver is a six wire device. As with the Tachsyn®, two of the wires are a high frequency excitation signal. The remaining four wires are outputs which supply commutation, velocity, and position information to the controller. These four wires are separated into two distinct pairs: sine (S1 and S3) and cosine (S2 and S4). Hence

the six wires are segregated into three pairs. Each pair must be run in a separate shield to insure proper motor operation.

The resolver must always be wired as shown in Figure D-4b. Any other wiring scheme may result in improper motor operation.

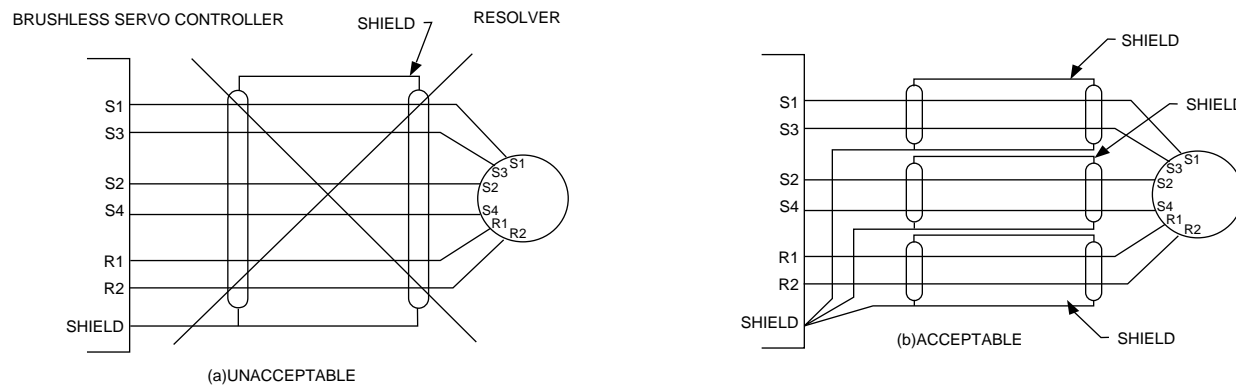

Figure D-4. Resolver Wiring

GROUNDING

The grounding procedures listed in the controller instructions should be followed. In general, the following rules should be observed.

All component chassis ground points and signal ground or common points should be tied together at a single point (star connection). This point should then be tied with a single conductor to an earth ground point. This form of grounding prevents ground loops and insures that all components are properly grounded against shock hazard.

SHIELDING

In general, it is good practice to shield all wires carrying low level signals. This is especially important if the signal level wires are run near power level wiring such as motor wires or relay wires.

When shielding wires, connect only one end of the shield, preferably the source end. Connecting both ends of a shield will result in ground loops. It is recommended that the unconnected end of the shield be insulated to prevent accidental connection.